



LCD MODULE SPECIFICATION

Customer: _____
Model Name: HC033IX60026-C05
Date: 2020/11/21
Version: 01

- Preliminary Specification
 Final Specification

For Customer's Acceptance

Approved by	Comment

Approved by	Reviewed by	Prepared by

Table of Contents

Table of Contents.....	2
Record of Revision	3
1 General Specifications	4
2 Input/Output Terminals.....	5
3 Absolute Maximum Ratings	6
4 Electrical Characteristics.....	7
5 Timing Chart	9
6 Optical Characteristics	13
7 Environmental / Reliability Tests.....	16
8 Mechanical Drawing	17
9 Packing Drawing.....	18
10 Precautions for Use of LCD Modules	19

1 General Specifications

Feature		Spec
Display Spec.	Size	3.34inch
	Resolution	320(RGB) X 320
	Interface	MIPI (Command Mode)
	Color Depth	16M dithering
	Technology Type	a-si TFT
	Pixel pitch(mm)	0.1875 x 0.1875
	Pixel Configuration	R.G.B. Vertical Stripe
	Display Mode	TM with Normally White
	Surface Treatment	HC
	Viewing Direction	12 o'clock
	Gray Scale Inversion Direction	6 o'clock
Mechanical Characteristics	LCM (W x H x D) (mm)	66.20×69.30×2.66 (Not include FPC dimension)
	Active Area(mm)	Diameter 60mm
	Driver IC	ST7796SI
	Weight (g)	TBD
	LED Numbers	6 LEDs Serial

Note 1: Requirements on Environmental Protection: Q/S0002

Note 2: LCM weight tolerance: $\pm 5\%$

2 Input/Output Terminals

2.1 TFT LCD Panel

No	Symbol	I/O	Description
1	GND	P	Ground
2	RST	I	Global reset signal
3	GND	P	Ground
4	MIPI_Data-N	I	MIPI Clock
5	MIPI_Data-P	I	MIPI Clock
6	GND	P	Ground
7	MIPI_CLK-N	I	MIPI Data
8	MIPI_CLK-P	I	MIPI Data
9	GND	P	Ground
10	TE	O	Tearing effect output
11	GND	P	Ground
12	VDD	P	Analog power supply
13	VDDIO	P	Digital power supply
14	GND	P	Ground
15	LEDA	P	LED Anode
16	LEDK	P	LED Cathode
17	GND	P	Ground

Note 1: I—Input, O—Output, P—Power/Ground, VCC=VDD

Table 2.1 Terminal pin assignments

3 Absolute Maximum Ratings

3.1 Driving TFT LCD Panel

Ta =25°C

Item	Symbol	MIN	MAX	Unit	Remark
Power Supply Voltage	VDD	-0.3	4	V	
Back Light Forward Current	ILED		25	mA	One LED
Operating Temperature	T _{OPR}	-20	70	°C	
Storage Temperature	T _{STG}	-30	80	°C	
Relative Humidity Note2	RH	--	≤95	%	Ta≤40°C
		--	≤85	%	40°C < Ta ≤50°C
		--	≤55	%	50°C < Ta ≤60°C
		--	≤36	%	60°C < Ta ≤70°C
		--	≤24	%	70°C < Ta ≤80°C
Absolute Humidity	AH	--	≤70	g/m ³	Ta > 70°C

Table 3.1 absolute maximum rating

Notes:

1. In case of below 0°C, the response time of liquid crystal (LC) becomes slower.
2. The color of panel becomes darker than normal one. Level of retardation depends on temperature, because of LC's characteristics.
3. If the module is above these absolute maximum ratings. It may become permanently damaged. Using the module within the following electrical characteristic conditions are also exceeded, the module will malfunction and cause poor reliability.

4 Electrical Characteristics

4.1 Driving TFT LCD Panel

GND=0V, Ta=25°C

Item	Symbol	MIN	TYP	MAX	Unit	Remark	
Supply Voltage	VDD	2.5	2.8	3.6	V		
IO Supply Voltage	VDDI	1.65	2.8	VDD	V	Connect to VDD internal.	
Input Signal Voltage	Low Level	VIL	DGND	—	0.3 VDDI	V	
	High Level	VIH	0.7 VDDI	—	VDDI	V	
Output Signal Voltage	Low Level	VOL	DGND	—	0.2VDDI	V	
	High Level	VOH	0.8VDDI	—	VDDI	V	
(Panel+LSI) Power Consumption	Black Mode (60Hz)				mA	Note 1,3,4	
	Sleep Mode				mA	Note 3,4	

Table 4.1 LCD module electrical characteristics

Notes:

1. All pixels black.
2. All pixels white.
3. Typical: VDDI=1.8V, VDD=2.8V; Maximum: VDDI=3.3V, VDD=3.3V
4. The power consumption was only reference

4.2 Backlight Unit

Ta=25°C

Item	Symbol	Min	Typ	Max	Unit	Remark
Forward Current	I_F	18	20	25	mA	6 LEDs (6 LED Serial,)
Forward Voltage	V_F	16.8	18.0	19.2	V	
Operating Life Time	-	20,000	-	-	Hrs	

Note1: The LED driving condition is defined for each LED module (6 LED Serial,).For each LED: $I_F = 20\text{mA}$, $V_F (1/6) = 3.2\text{V}$.

Note2: Under LCM operating, the stable forward current should be inputted. And forward voltage is for reference only.

Note3: I_F is defined for one channel LED. Optical performance should be evaluated at Ta=25°C only If LED is driven by high current, high ambient temperature & humidity condition. The life time of LED will be reduced. Operating life means brightness goes down to 50% initial brightness. Typical operating life time is estimated data.

Note4: The LED driving condition is defined for each LED



4.3 Block Diagram LCD module diagram

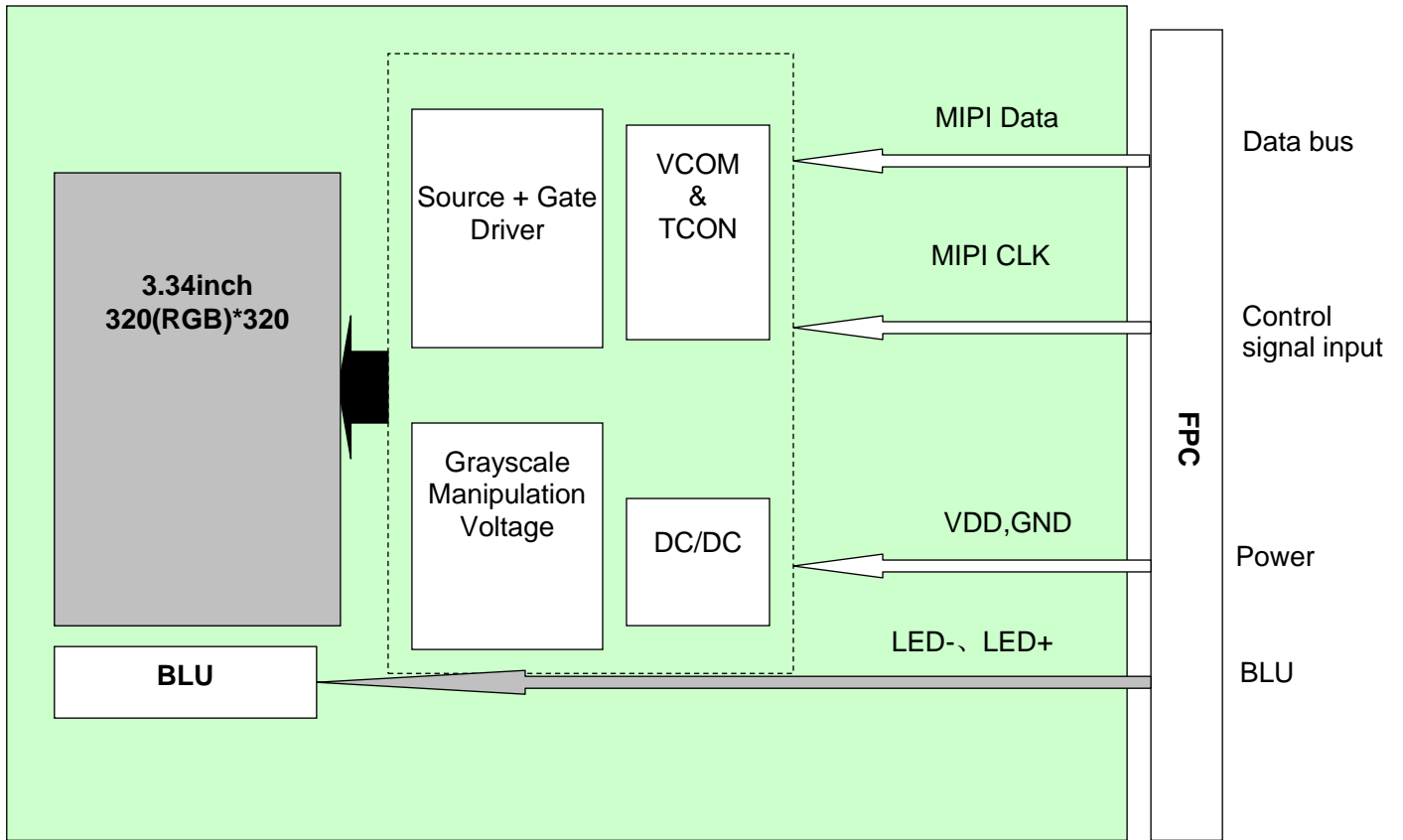

5 Timing Chart

5.1 INTERFACE TIMING

High Speed Mode – Clock Channel Timing

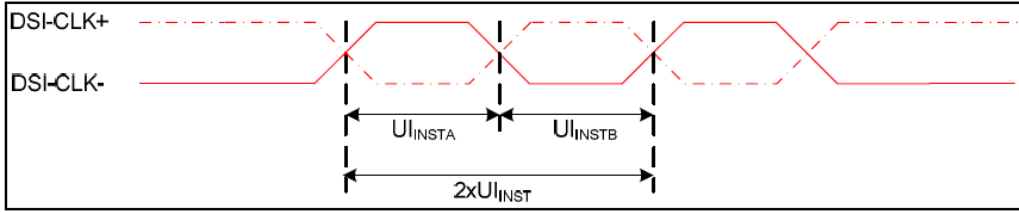

VDDI=1.8V, VDDA=2.8V, AGND=DGND=0V, Ta=25 °C

Signal	Symbol	Parameter	MIN	MAX	Unit	Description
DSI-DATA_P/N	2xUI INST	Double UI instantaneous	4	25	ns	
DSI-DATA_P/N	UI INSTA ,UI INSTB	UI instantaneous Half	2	12.5	ns	

5.2 Reset Timing

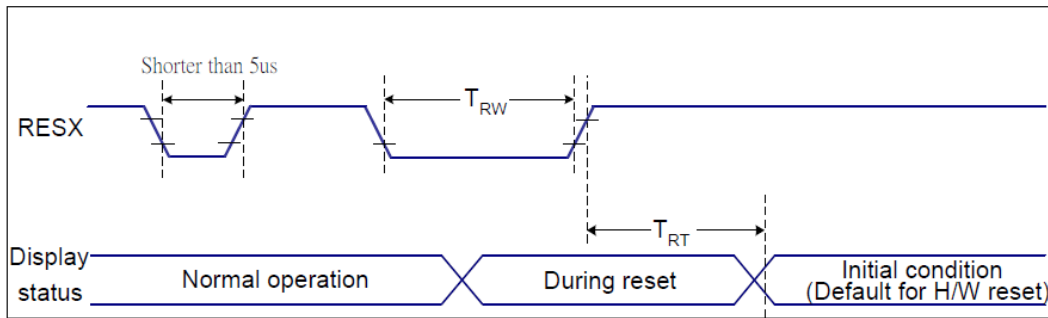

Reset Timing

VDDI=1.8V, VDDA=2.8V, AGND=DGND=0V, Ta=25 °C

Related Pins	Symbol	Parameter	MIN	MAX	Unit
RESX	TRW	Reset pulse duration	10	-	us
	TRT	Reset cancel	-	5 (Note 1, 5) 120 (Note 1, 6, 7)	ms

Table 1 Reset Timing

Notes:

- The reset cancel includes also required time for loading ID bytes, VCOM setting and other settings from NVM (or similar device) to registers. This loading is done every time when there is HW reset cancel time (tRT) within 5 ms after a rising edge of RESX.
- Spike due to an electrostatic discharge on RESX line does not cause irregular system reset according to the table below.

RESX Pulse	Action
Shorter than 5us	Reset Rejected
Longer than 9us	Reset
Between 5us and 9us	Reset starts

3. During the Resetting period, the display will be blanked (The display is entering blanking sequence, which maximum time is 120 ms, when Reset Starts in Sleep Out –mode. The display remains the blank state in Sleep In –mode.) and then return to Default condition for Hardware Reset.

4. Spike Rejection also applies during a valid reset pulse as shown below:

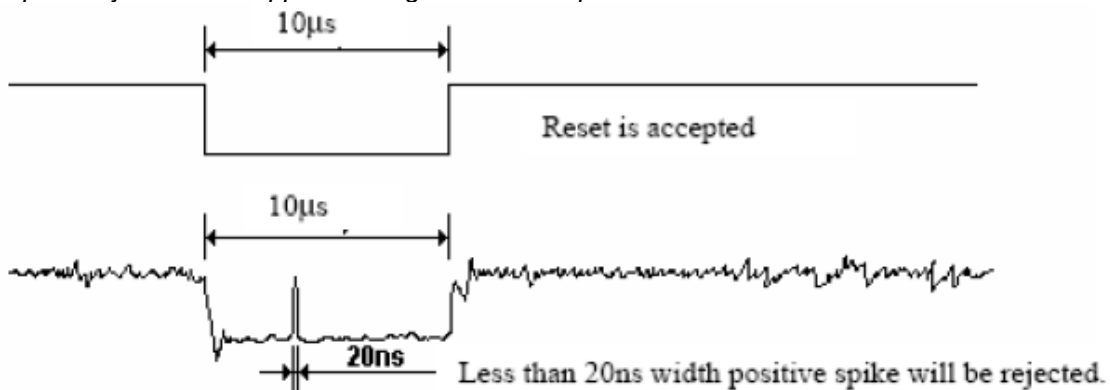

5. When Reset applied during Sleep In Mode.

6. When Reset applied during Sleep Out Mode.

7. It is necessary to wait 5msec after releasing RESX before sending commands. Also Sleep Out command cannot be sent for 120msec.

5. 3 Power-On Sequence

The power on sequence:

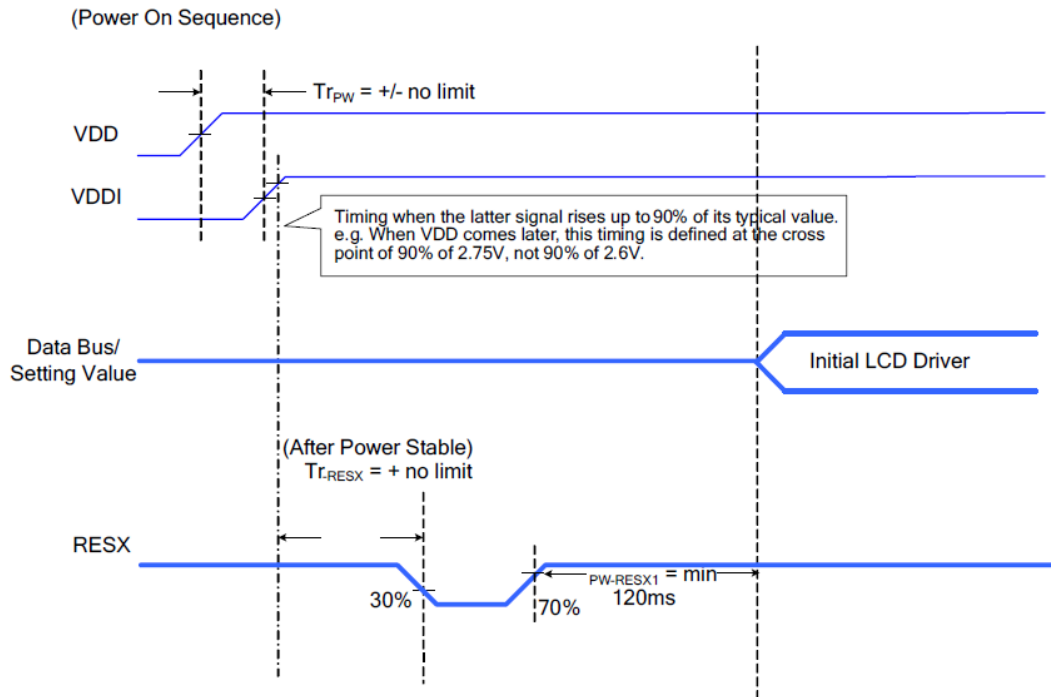

5. 4 Power-Off Sequence

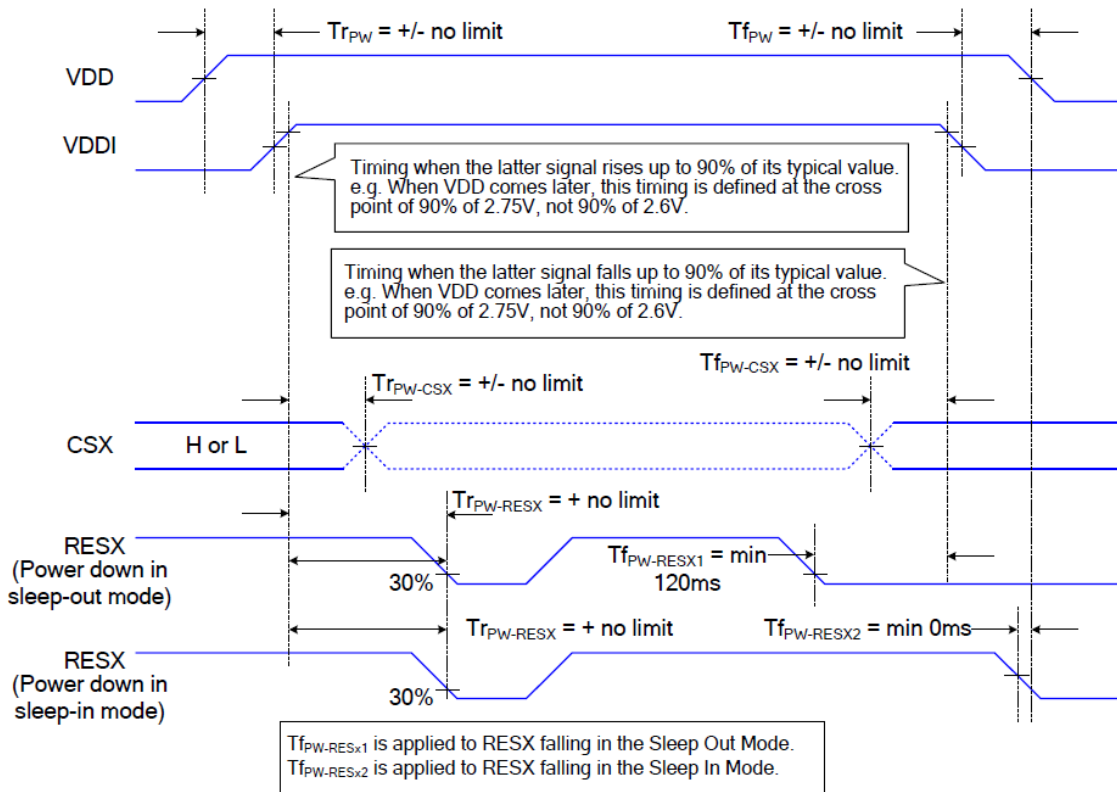

Note: Please refer to ST7796SI data sheet for more details. ST7796SI INTERFACE PROTOCOL

6 Optical Characteristics

Ta=25°C

Item	Symbol	Condition	Min	Typ	Max	Unit	Remark	
View Angles	θT	CR \geq 10	60	70	-	Degree	Note2,3	
	θB		70	80	-			
	θL		70	80	-			
	θR		70	80	-			
Contrast Ratio	CR	$\theta=0^\circ$	600	800	-		Note 3	
Response Time	T _{ON}	25°C	-	20	30	ms	Note 4	
	T _{OFF}							
Chromaticity	White	Backlight is on	x	0.235	0.285	0.335	-	Note 1,5
			y	0.258	0.308	0.358		
	Red		x	0.535	0.585	0.635		Note 1,5
			y	0.274	0.324	0.374		
	Green		x	0.289	0.339	0.389		Note 1,5
			y	0.537	0.587	0.637		
	Blue		x	0.101	0.151	0.201		Note 1,5
			y	0.038	0.088	0.138		
Uniformity	U		70	75	-	%	Note 6	
NTSC			45	50	-	%	Note 5	
Luminance(without lens)	L		600	-	-	cd/m ²	Note 7	

Test Conditions:

1. I_F= 20 mA, and the ambient temperature is 25°C.
2. The test systems refer to Note 1 and Note 2.

Note 1: Definition of optical measurement system.

The optical characteristics should be measured in dark room. After 5 Minutes operation, the optical properties are measured at the center point of the LCD screen. All input terminals LCD panel must be ground when measuring the center area of the panel.

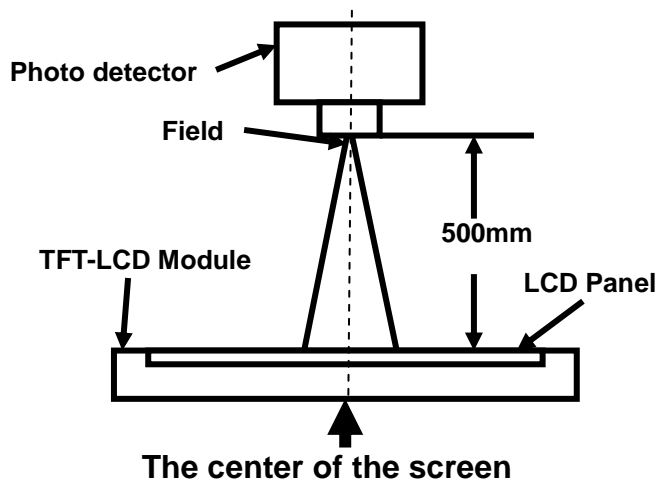

Note 2: Definition of viewing angle range and measurement system.

viewing angle is measured at the center point of the LCD by CONOSCOPE(ergo-80).

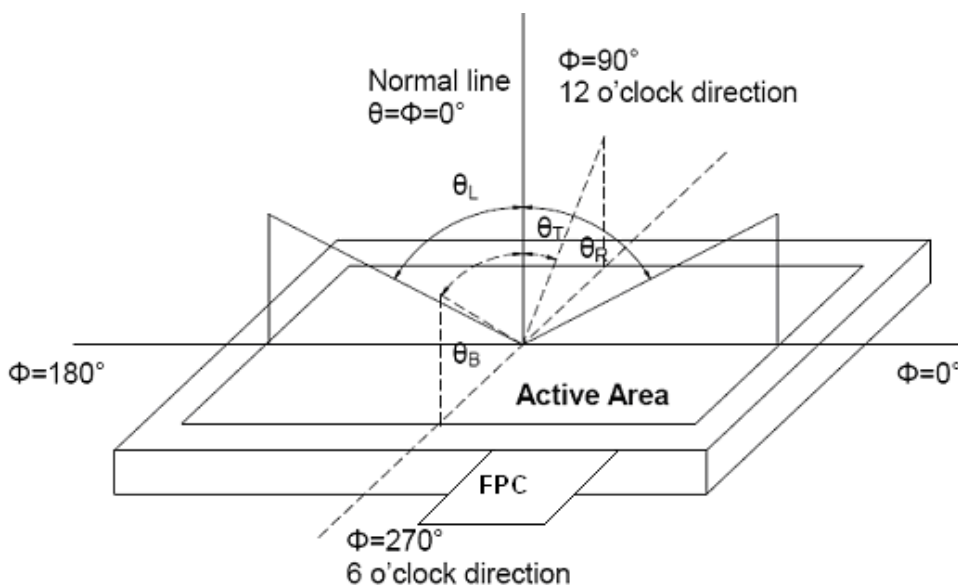

Note 3: Definition of contrast ratio

$$\text{Contrast ratio (CR)} = \frac{\text{Luminance measured when LCD is on the "White" state}}{\text{Luminance measured when LCD is on the "Black" state}}$$

“White state “: The state is that the LCD should drive by V_{white} .

“Black state”: The state is that the LCD should drive by V_{black} .

V_{white} : TBD V V_{black} : TBD V.

Note 4: Definition of Response time

The response time is defined as the LCD optical switching time interval between “White” state and “Black” state. Rise time (T_{ON}) is the time between photo detector output intensity changed from 90% to 10%. And fall time (T_{OFF}) is the time between photo detector output intensity changed from 10% to 90%.

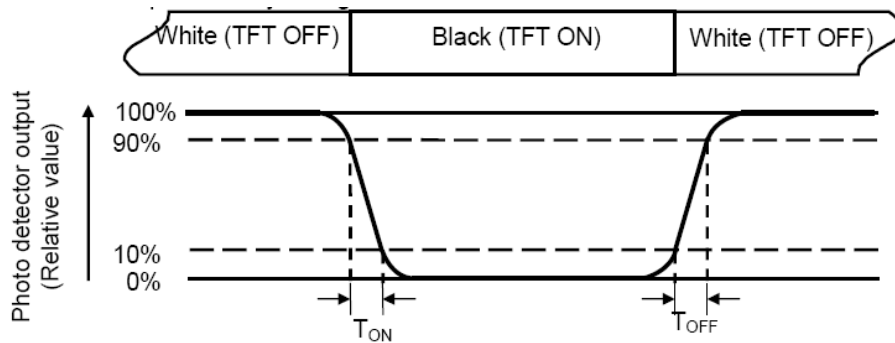

Note 5: Definition of color chromaticity (CIE1931)

Color coordinates measured at center point of LCD.

Note 6: Definition of Luminance Uniformity

Active area is divided into 9 measuring areas (Refer Fig. 2). Every measuring point is placed at the center of each measuring area.

$$\text{Luminance Uniformity (U)} = L_{\min} / L_{\max}$$

L-----Active area length W----- Active area width

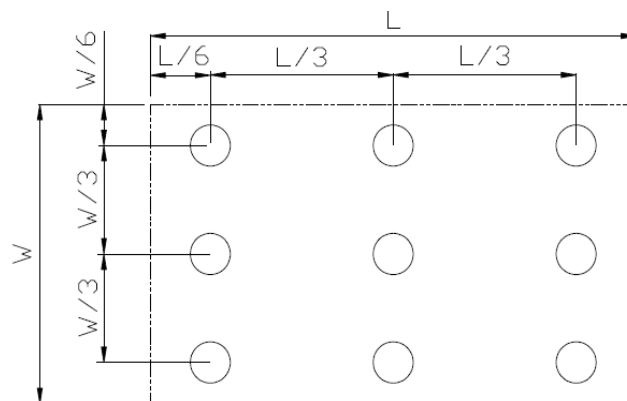

L_{\max} : The measured Maximum luminance of all measurement position.

L_{\min} : The measured Minimum luminance of all measurement position.

Note 7: Definition of Luminance:

Measure the luminance of white state at center point.

7 Environmental / Reliability Tests

No	Test Item	Condition	Remarks
1	High Temperature Operation	Ts=+70°C, 160hrs	Note1 IEC60068-2-1,GB2423.2
2	Low Temperature Operation	Ta=-20°C, 160hrs	IEC60068-2-1 GB2423.1
3	High Temperature Storage	Ta=+80°C, 160hrs	IEC60068-2-1 GB2423.2
4	Low Temperature Storage	Ta=-30°C, 160hrs	IEC60068-2-1 GB2423.1
5	High Temperature & High Humidity Storage	Ta=+60°C, 90% RH 160 hours	Note2 IEC60068-2-78 GB/T2423.3
6	Thermal Shock (Non-operation)	-20°C 30 min ~ +60°C 30 min, Change time: 1min, 100 Cycles	Start with cold temperature, End with high temperature, IEC60068-2-14,GB2423.22
7	Electro Static Discharge (Operation)	C=150pF, R=330Ω · 5points/panel Air:±4KV, 5times; Contact:±2KV, 5 times; (Environment: 15°C~35°C, 30%~60%, 86Kpa~106Kpa)	IEC61000-4-2 GB/T17626.2 Class B
8	Package Vibration Test	Frequency range:10~55Hz, Stroke:1.5mm Sweep:10Hz~55Hz~10Hz 2 hours for each direction of X.Y.Z. (6 hours for total)(Package condition)	IEC60068-2-6 GB/T2423.10
9	Shock (Non-operation)	60G 6ms, ±X,±Y,±Z 3times, for each direction	IEC60068-2-27 GB/T2423.5
10	Package Drop Test	Height:60 cm, 1 corner, 3 edges, 6 surfaces	IEC60068-2-32 GB/T2423.8

Note1: Ts is the temperature of panel's surface.

Note2: Ta is the ambient temperature of sample.

Note3: Before cosmetic and function test, the product must have enough recovery time, at least 2 hours at room temperature.

Note 4: In the standard condition, there shall be no practical problem that may affect the display function. After the reliability test, the product only guarantees operation, but don't guarantee all of the cosmetic specification.

9 Packing Drawing

No	Item	Model (Material)	Dimensions(mm)	Unit Weight(Kg)	Quantity	Remark
1	LCM module			TBD	126	
2	Tray	YBZ1-00	251×351×13.5	TBD	24	
3	EPE1	MBZ-ZZML1	336×246×6mm	TBD	6	
4	EPE2	MBZ-ZZM15	375×275×10mm	TBD	4	
5	EPE3	MBZ-ZZM16	250×280×12mm	TBD	2	
6	Carton	X18A	395×290×315mm	TBD	1	
7	ES bag	JD13	400×520	TBD	3	
8	Total weight	TBD±5% Kg				

10 Precautions for Use of LCD Modules

10.1 Handling Precautions

10.1.1 The display panel is made of glass. Do not subject it to a mechanical shock by dropping it from a high place, etc.

10.1.2 If the display panel is damaged and the liquid crystal substance inside it leaks out, be sure not to get any in your mouth, if the substance comes into contact with your skin or clothes, promptly wash it off using soap and water.

10.1.3 Do not apply excessive force to the display surface or the adjoining areas since this may cause the color tone to vary.

10.1.4 The polarizer covering the display surface of the LCD module is soft and easily scratched. Handle this polarizer carefully.

10.1.5 If the display surface is contaminated, breathe on the surface and gently wipe it with a soft dry cloth. If still not completely clear, moisten cloth with one of the following solvents:

- Isopropyl alcohol
- Ethyl alcohol

Solvents other than those mentioned above may damage the polarizer. Especially, do not use the following:

- Ketone
- Aromatic solvents

10.1.6 Do not attempt to disassemble the LCD Module.

10.1.7 If the logic circuit power is off, do not apply the input signals.

10.1.8 To prevent destruction of the elements by static electricity, be careful to maintain an optimum work environment.

10.1.8.1 Be sure to ground the body when handling the LCD Modules.

10.1.8.2 Tools required for assembly, such as soldering irons, must be properly ground.

10.1.8.3 To reduce the amount of static electricity generated, do not conduct assembly and other work under dry conditions.

10.1.8.4 The LCD Module is coated with a film to protect the display surface. Be care when peeling off this protective film since static electricity may be generated.

10.2 Storage precautions

10.2.1 When storing the LCD modules, avoid exposure to direct sunlight or to the light of fluorescent lamps.

10.2.2 The LCD modules should be stored under the storage temperature range. If the LCD modules will be stored for a long time, the recommend condition is:

Temperature : 0°C ~ 40°C Relatively humidity: ≤80%

10.2.3 The LCD modules should be stored in the room without acid, alkali and harmful gas.

10.3 Transportation Precautions

10.3.1 The LCD modules should be no falling and violent shocking during transportation, and also should avoid excessive press, water, damp and sunshine.